

E+G GN 817 - NI positioneringsbolt

Greb, Maskin-, DIN- & Normdele > E+G Positionerings-elementer > E+G Positioneringsbolte > E+G Pos. bolte u/stopspærre > E+G GN



Vare:
Beskrivelse:

20265036
E+G
Positioneringsbolt GN
817-10-12-G-NI

<https://test.brd-kee.dk/produkter/20265036>

Mål

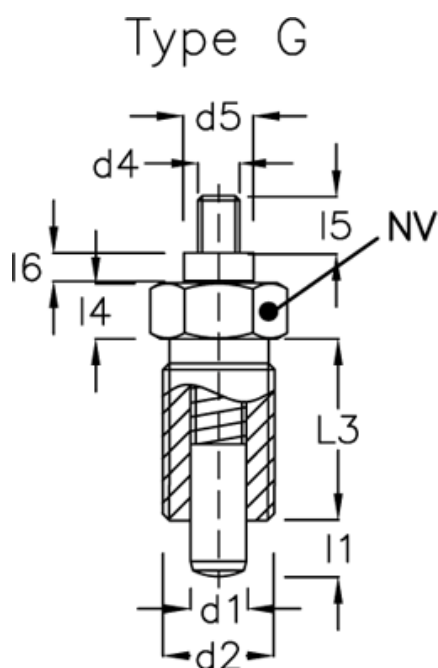

Type G
(åben)

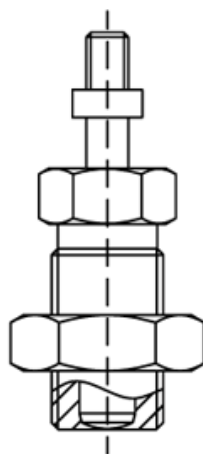

d1	=	10
d2	=	M16x1,5
d4	=	M6
d5	=	10
l1	=	12
l3	=	26
l4	=	8
l5	=	8.5
l6	=	4.0
NV	=	17

Fjedertryk N bund: 38.0

Fjedertryk N top: 9.5

Dokumenter, målskitser og brochurer af enhver slags kan indeholde fejl for hvilke Brd. Klee A/S ikke hæfter.